



SURGE PROTECTION

OUTDOOR LED
LIGHTING



THE NEED FOR PROTECTION

Why is protection needed?

LED technology has become the reference technology for lighting, mainly because of four characteristics: **efficiency, versatility, energy savings and longer life.**

In spite of these benefits, the technology has a number of drawbacks: Higher cost of implementation (initial investment) and internal electronics (LED optics and drivers), much more complex and sensitive to overvoltages than in the case of traditional light sources.

For these reasons, **the use of overvoltage protection systems is a very cost-effective investment**, since it extends the life of the luminaires, ensures the cost effectiveness (ROI) of LED projects and reduces the costs of maintenance and replacement of luminaires.

A surge protection device (SPD) connected upstream of the driver, complements the intrinsic immunity of the luminaire, creating much more robust protection against the effects of lightning and overvoltages.

Overview

Luminaires with LED technology are used in a large number of applications where overall exposure to atmospheric phenomena is generally high: **street lighting, tunnels, public lighting, stadiums, industries, etc.**

Overvoltages can be subdivided into 5 different types

1. **Increased earth potential** due to a nearby strike, depending on the resistivity of physical earth.
2. **Switching** due to normal operation. (e.g. all the luminaires being switched on at once).
3. **Induced** in the circuitry: resulting from the electromagnetic field of a nearby (<500 m) strike.
4. **Direct strike** on a luminaire or supply lines.
5. **Permanent or temporary overvoltages (POP)** due to supply problems

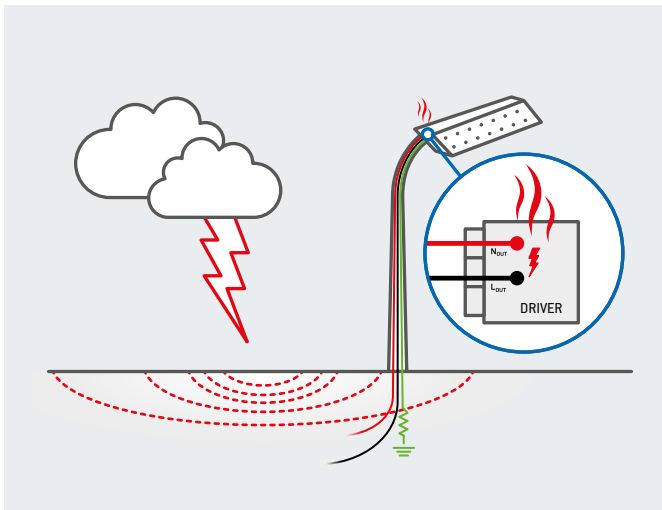

The likelihood of a voltage surge caused by a lightning strike or induction is usually very high in lighting installations, although the risk is determined by the nature of the installation (indoors, outdoors) and the degree of exposure (elevated locations, isolated sites, cable extensions, etc.).

Damage and cost of repairs

- Drivers usually have a certain level of immunity (2 to 4 kV) to transient overvoltages. This is enough to pass the tests for luminaires but insufficient to withstand voltage surges caused by lightning (10 kV/10 kA) under field conditions.
- The experience of the installed base of the LED lighting industry has shown that **without a proper SPD, a high percentage of luminaires reach end of life prematurely.** This leads to a number of costs for the replacement of equipment, maintenance costs, continuity of service, etc which end up adversely affecting project ROIs and their image.
- Continuity of service is vital in lighting installations where good illumination is a key safety issue (crime, road safety, workplace lighting, etc.).
- Proper sizing of an “SPD + luminaire” system ensures that repeated overvoltage events do not lead to driver end-of-life, or not before the SPD in the worst case. This translates into cost savings, especially because of the reduction of corrective maintenance actions.

Comprehensive protection

Surge protection devices (SPD) protect equipment by discharging the overvoltage to earth, thus limiting the voltage reaching the equipment (residual voltage).

An effective overvoltage protection design comprises staggered protection, with stages for each of the sensitive components in the system. In this way part of the overvoltage is discharged in each protection stage until only a small residual voltage is left close to the luminaire.

Protection in the lighting panel 1 although necessary, is by itself insufficient because overvoltages can also be induced in long cable runs, which means that the final protection should always be as close as possible to the equipment being protected 2 3.

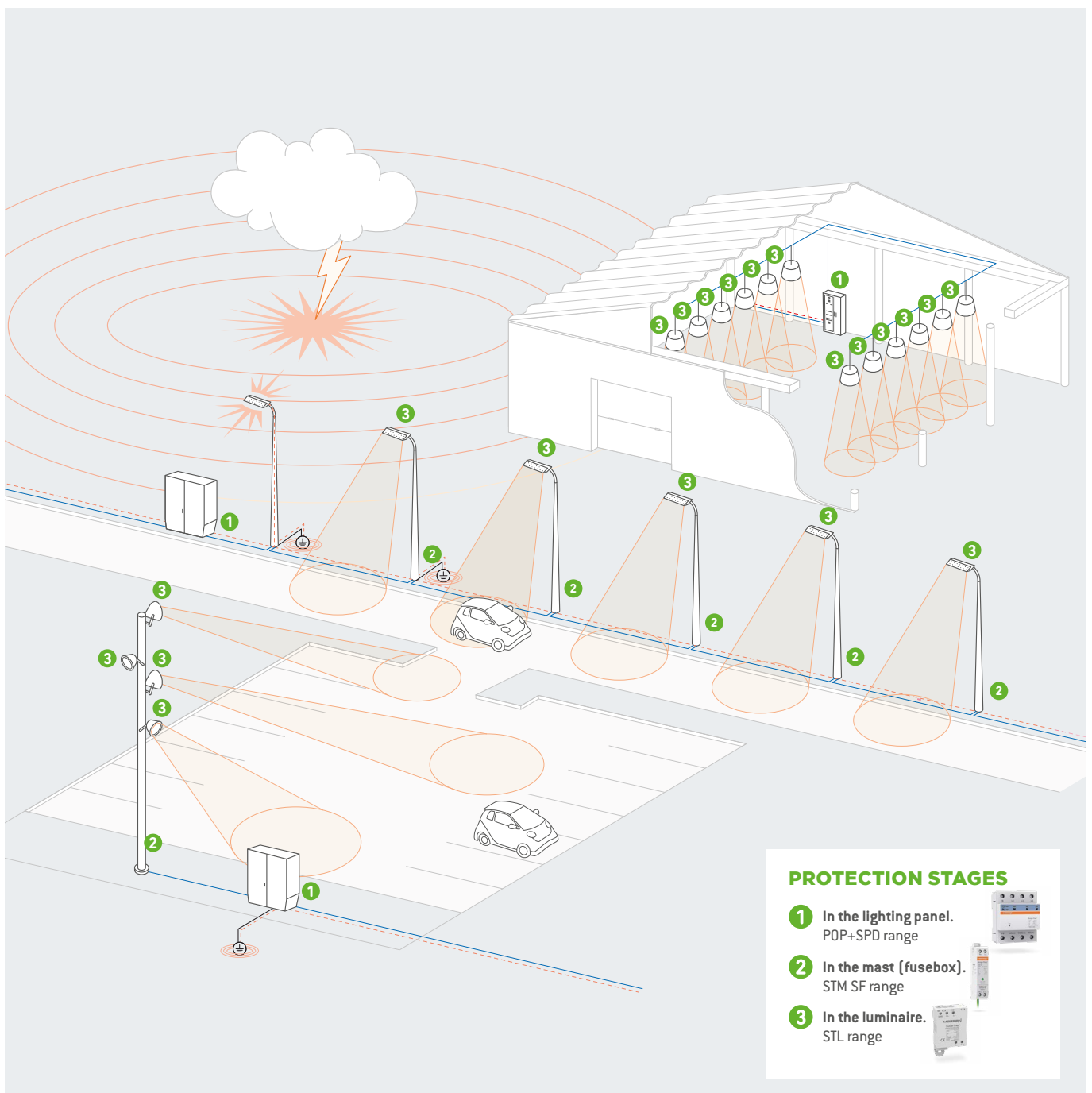

KEY DESIGN PRINCIPLES FOR THE BEST PROTECTION

Cascade protection

Location of protection

The typical configuration of an outdoor lighting installation consists of a general lighting panel and a set of luminaires with long cable runs between them, and between them and the panel.

For effective protection in a system like this, it is essential to have staggered protection with high discharge capacity and low residual voltage. This requires a minimum of two stages of protection (see table).

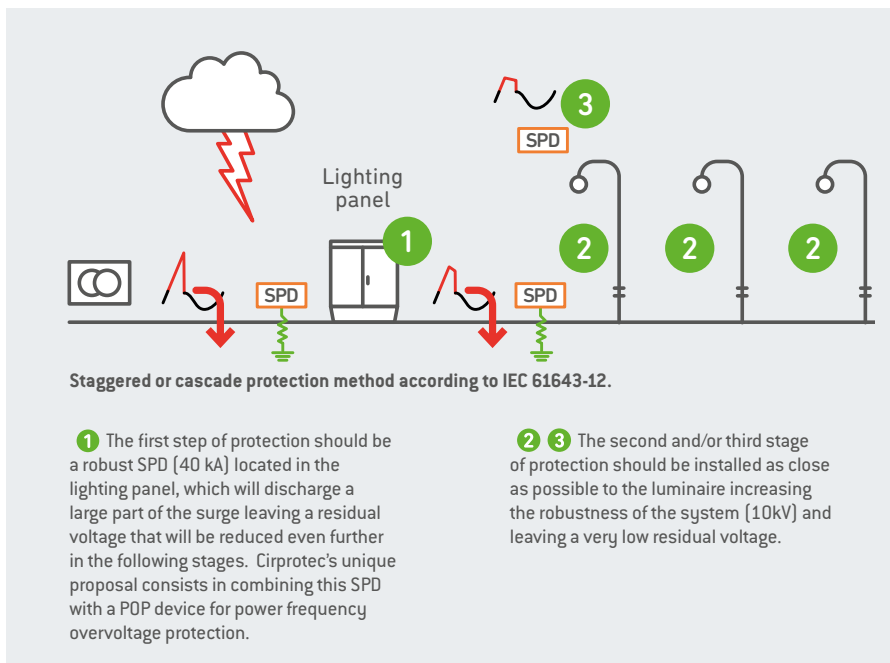

Protection - in series or parallel

Surge protection devices (SPD) can be connected in series or parallel as shown in the image. Each has its advantages and disadvantages

Parallel: if the SPD reaches end-of-life the luminaire will remain connected, giving priority to continuity of service.

Series: if the SPD reaches end-of-life the luminaire will be turned off, giving priority to protection. This connection is recommended because it makes it possible to know if any SPD has reached its end-of-life. This avoids having to open each luminaire to check the status of the arrester.

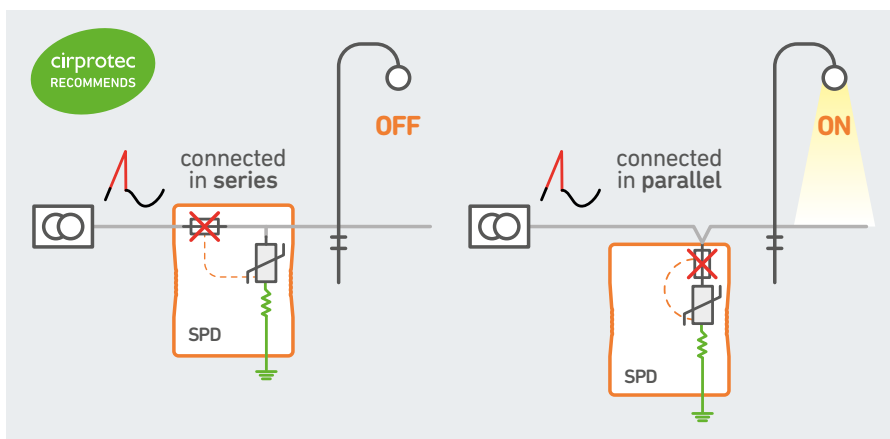

Safety and universality

Safety and universality are key issues in both the design and the installation of the luminaire, since this provides comfort and peace-of-mind to the installer or specifier/client. Since the manufacturer often does not know where or how the luminaire is installed, only a UNIVERSAL, SAFE SPD provides a guarantee of proper operation in all cases.

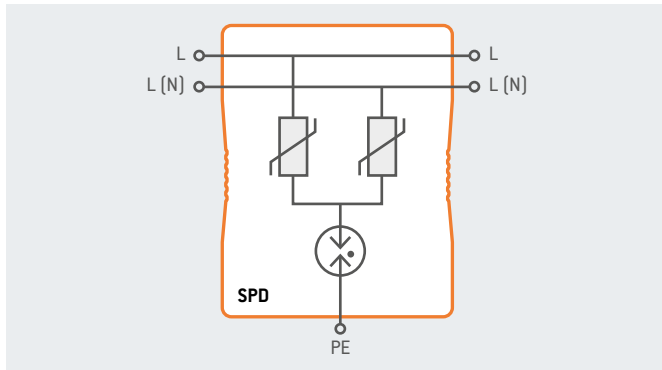

How is the luminaire installed?

- **The standard (IEC 60598), requires that at no time in its life should an SPD generate leakage currents.** To achieve this, a component called a gas discharge tube (GDT) is used, which is not suitable on its own for the Line- PE connection. Since the L-PE connection is crucial to the safety and universality of SPDs, **the solution is to use a symmetrical protection circuit** so that in common mode the SPD will always have a varistor (MOV) in series with GDT to PE.
- **Wiring errors.** Inverting L and N is a typical error that can cause an electrical hazard in the event of a surge but which is not detected during installation.
- **SPD wiring in series or parallel.** A compromise between continuity of service and protection for the luminaire. It's for the final customer to decide.

Where is the luminaire installed?

- IT, TT, TN networks. A standard SPD cannot withstand a line-to-earth fault in 120/230 V networks.
- 230 V L-N or L-L networks. These networks are common in several regions and situations, not all SPDs can be connected L-L.

Suitable for all installations worldwide

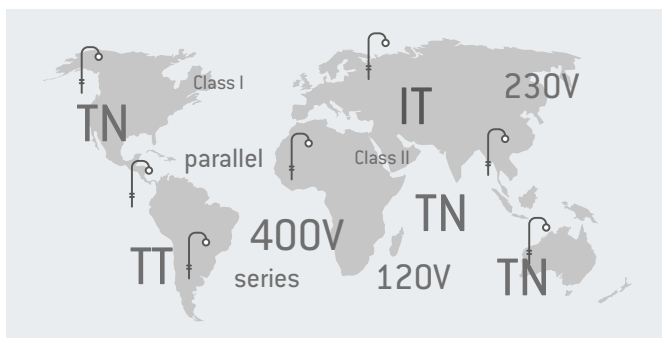

Common and differential mode

Surge may occur in differential mode, between live L-N conductors or in common mode between live conductors and earth.

Surge in common mode, typical of direct lighting strikes and increases in earth potential, are more destructive than in differential mode, so it is very important to provide earth protection for both Class 1 and Class 2 luminaires. In the majority of Class 2 systems the luminaire mast is made of metal and can generate an arc of tens of kilovolts between the metal structure and the circuitry. An arrester with common mode protection ensures this problem does not arise.

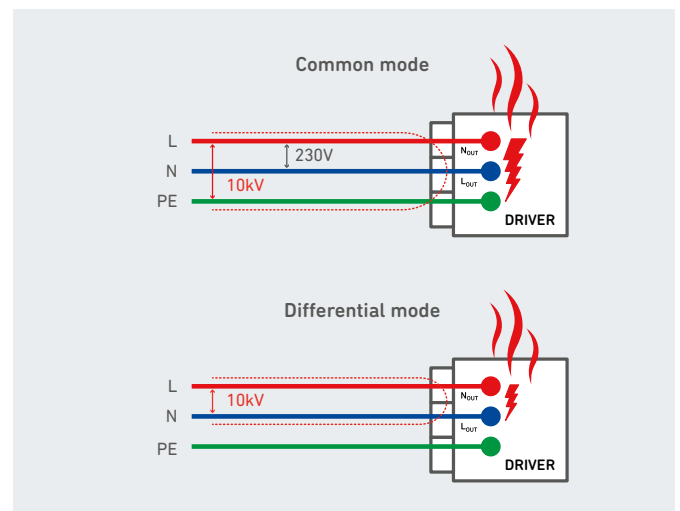

POP protection

Temporary or permanent overvoltages (POP) are increases in voltage of more than 20% of nominal voltage up to 400 V for several seconds, minutes or hours. These overvoltages are usually due to breakage of the neutral or to unbalanced loads. The only way to protect against such events is to disconnect the load, in this case through the contactor.

Temporary overvoltage protection - POP, adds value to the installation:

- Automatic reconnection via the contactor in the lighting panel.
- Tripping curve in accordance with EN 50550.

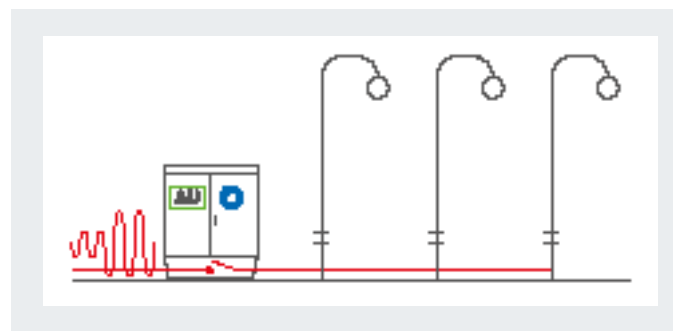

NSB RANGE

THE MOST VERSATILE SPD ON THE MARKET

NSB is the new range of compact SPDs for LED luminaires

This universal solution supports all network configurations (TN, IT, TT) and luminaire insulation classes (I & II). This range includes a series of connectors, flexible fixing and optional IP66 rating.

Quality

CB Scheme certification (issued by **DEKRA**) where all points of IEC 61643-11 have been tested.



Universal solutions

NSB guarantees the universality and safety of the luminaire:

- **For all network configurations** (TT, TN & IT) configurations.
- **Wiring safety** LN/NL reversible.
- **Universality** L-N 230 V, L-L 230 V
- **Series/parallel** wiring.



Wide range

Multiple electrical configurations to provide solutions to the various market requirements, types of network and luminaire, and protection modes



DD connection WW IP connection WW connection

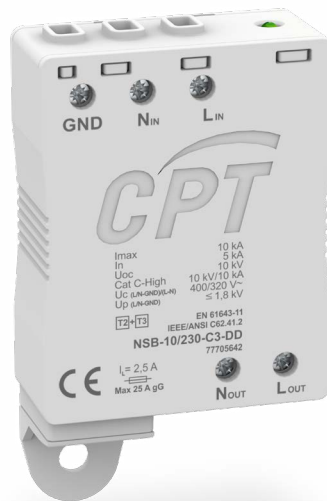

Double end-of-life indication

Disconnection If installed in series, the SPD will turn the luminaire off when it comes to its end-of-life.

Visual LED indication.

No leakage current

All NSBs with common mode protection have no leakage current to earth, thereby **preventing any possibility of the SPD generating dangerous contact voltages.**



Versatile connections

The fastening flange allows the SPD to be **installed upright or flat, depending on the space** constraints of the luminaire.

Luminaire OEMs can choose wiring solutions (IN/OUT) on the same side or opposite sides.

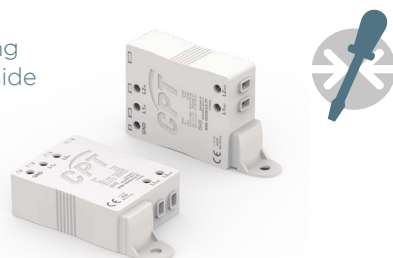

FOR LED LUMINAIRES

NSB

PARAMETERS	
T2 I _{max}	10 kA
T3 U _{oc}	10 kV
Nominal voltage	230 V
Series and parallel connections	All models
End-of-life indication	Optical + disconnect
No leakage current	All models
LN/NL reversible (Safety)	C3 models
230V L-N or L-L (Universal)	C3 models
TN, TT, IT (Universal)	All models
Available connection types	Wires in/out, terminal in/out
Versatile connections	IN/OUT on the same (WW) or opposite sides (DD)
	Dual fixing options
Modelos disponibles de IP66	IP models
Certificacion	CB-Scheme IEC 61643-11, UL 1449 for specific models

Models

REF. NUM	CATALOG NUMBER	DIAGRAM	WIRING	PU
77705642	NSB-10/230-C3-DD	C3	DD	100 pcs
77705652	NSB-10/230-C3-WW	C3	WW	40 pcs
77705640	NSB-10/230-C3-WW-IP	C3	WW	40 pcs
77705646	NSB-10/230-C4-DD	C4	DD	100 pcs

For other configurations consult the Cirprotec technical sales department.
The flanges are supplied loose to allow them to be arranged according to the location of the luminaire. Connections: DD terminal-terminal, WW wire-wire.

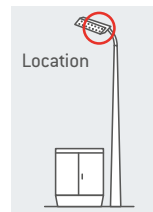

NSB



Dimensions

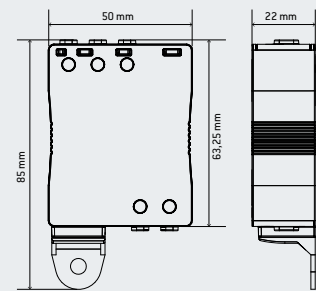

Internal configuration

Diagram C3

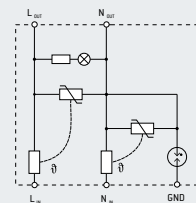

cirprotec
RECOMMENDS

Diagram C4

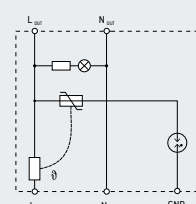

OTHER SOLUTIONS FOR LED LUMINAIRES

NSS The ultra-compact SPD for LED luminaires

NSS is the range of ultra-compact SPDs for LED luminaires. This universal solution supports all network configurations (TN, IT, TT) and luminaire insulation classes (I & II).

NSS

PARAMETERS	
T2 I _{max}	10 kA
T3 U _{oc}	10 kV
Nominal voltage	230 V
Series and parallel connections	YES
End-of-life indication	Optical + disconnect
LN/NL reversible (Safety)	YES
230 V L-N or L-L (Universal)	YES
TN, TT, IT (Universal)	YES
Available connection types	Wire IN, terminal OUT
Certification	CB-Scheme IEC 61643-11

Models

REF. NUM	CATALOG NUMBER	DIAGRAM	WIRING	PU
77705868	NSS-10/230-C12-P	C12	WD	40 ud

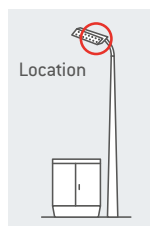

Internal configuration

Diagram C12

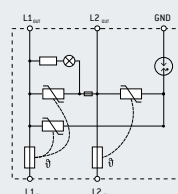

NSH Robust protection for floodlights

NSH is the new range of SPDs for special LED luminaire applications such as sports stadiums, parks and green areas where higher voltage and discharge capacity is needed: 20 kV and 480 V.

NSH

PARAMETERS	
T2 I _{max}	20 kA
T3 U _{oc}	20 kV
Nominal voltage	Up to 480 V
Series and parallel connections	YES
End-of-life indication	Optical + disconnect
No leakage current	YES
TN-TT-IT (Universal)	YES
L-L/ L-N reversible (Safety)	YES
Connection terminals	Wire IN/ push-in OUT
Certificaciones	CB-Scheme IEC 61643-11

Models

REF. NUM	CATALOG NUMBER
77705890	NSH-20/480-C3-WP

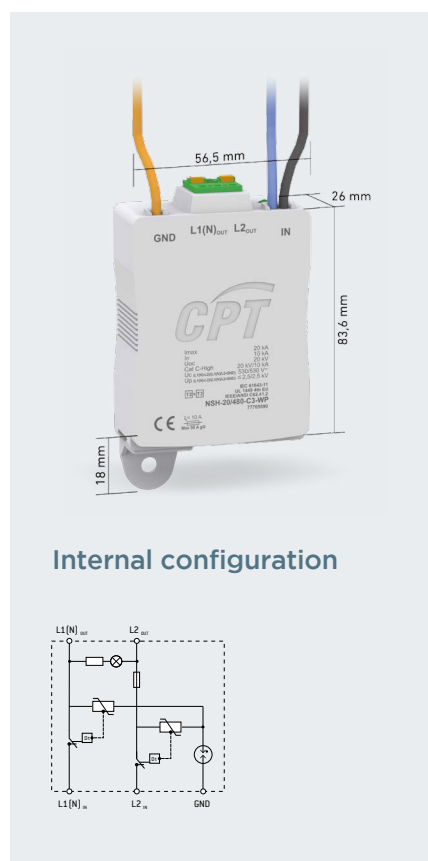
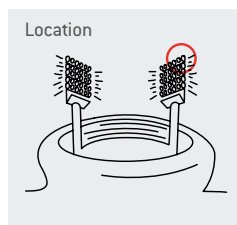

Internal configuration

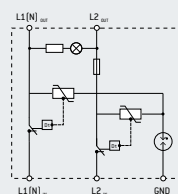

FUSEBOX & LIGHTING PANEL SOLUTIONS

CSF21 FB Compact DIN-rail protection for Fusebox

CSF21 FB is the new range of LED arresters which provides a **solution for installation in fuse boxes** (located in the mast of the luminaire) **with a DIN rail**.

CSF21 FB

PARAMETERS	
Uoc	10 kV
Uc- Max. DC voltage	320 V
I _{max}	10 kA
End-of-life indication	Optical + disconnect
Installation	DIN rail
Cables	Single phase (1Ph + N)
No leakage current	YES
Wiring	Series or parallel (both)
Protection modes	Common and differential mode

Models

REF. NUM	CATALOG NUMBER
CSF21-10/230 FB	STMT23-10K320V-SP-SF

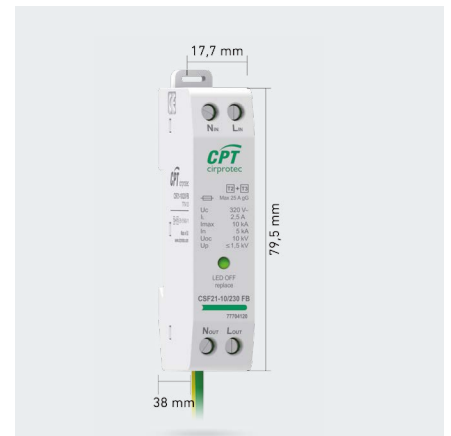
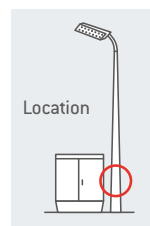

Internal configuration

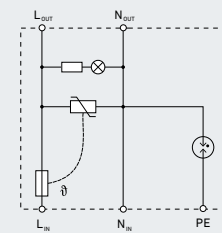

V-CHECK 4RC Robust SPD + POP in the panel

2 in 1. Combined protection - POP+SPD. Protection against permanent or temporary overvoltages (POP) is the perfect complement to the typical first stage protection, a type 2 SPD in the lighting panel.

V-CHECK 4RC

PARAMETERS	SPD	POP
IEC 61643 Classification	Type 2	
I _{max} (8/20)	40 kA	
Uc- Max. DC voltage	400 V	
End-of-life indication	LED	
Permanent overvoltage protection		YES
Actuation and reconnection		Via contactor (not included)
Auto reconnect after voltage stabilization		YES, via the contactor
Tripping times as per standard		EN 50550
Location	Lighting panel	
Remote indication available	YES	

Models

REF. NUM	CATALOG NUMBER
83060100	POP-40K230V-CT-4P
83060101	POP-40K230V-CT-4PM

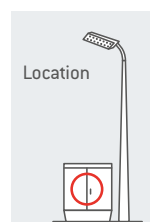

Internal configuration

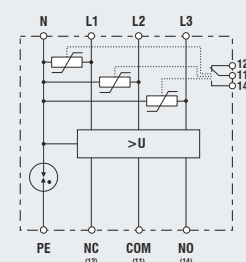

APPLICATIONS

A wide range of lighting applications, which by their nature and usage, make overvoltage protection particularly necessary. Good protection guarantees system operation (continuity of service), provides safety and helps protect the investment (ROI) in LED lighting equipment.

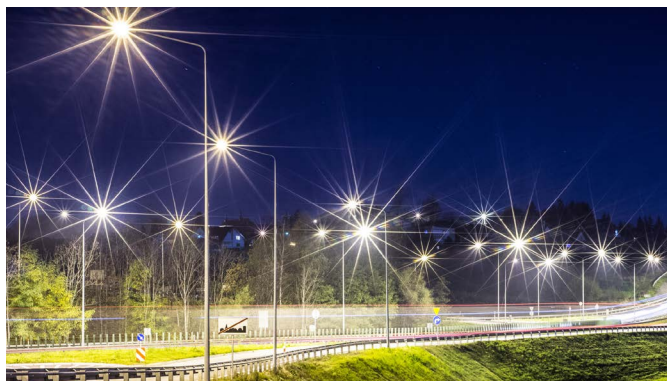

Street lighting



Industrial lighting

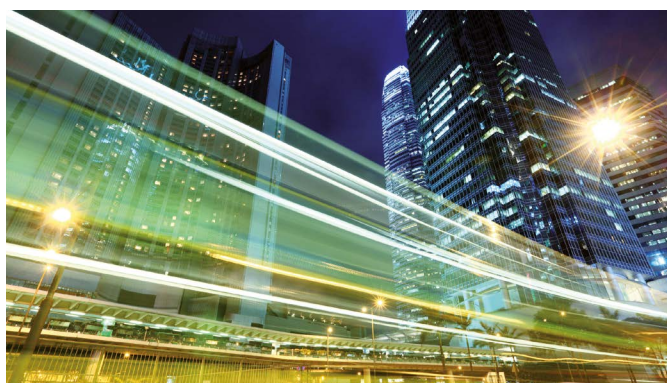

Public lighting



Car park

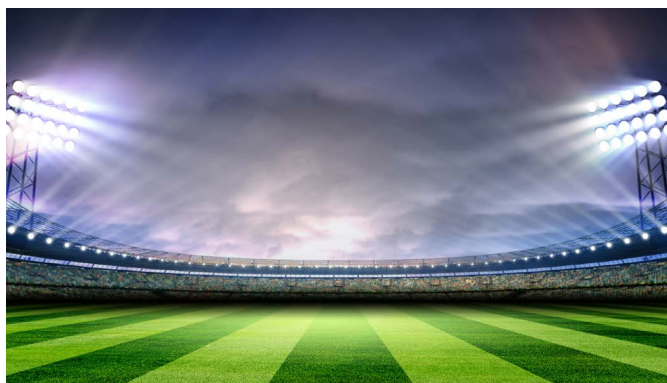

Stadiums



Tunnels

WHY CHOOSE CIRPROTEC?

Cirprotec, a specialist lightning and surge protection company, provides the market with a specific range for the protection of LED installations, the result of **over 20 years of experience in the industry.**

Your protection partner

We aim to be your partner in overvoltage protection, providing a **complete solution** in this field: a **wide product range, technical advice, made-to-measure products, luminaire testing, etc.**

Made-to-measure solutions

Cirprotec's R&D department is available to LED lighting manufacturers for the joint development of specific solutions.

THE LEADING MANUFACTURERS OF LED LUMINAIRES ARE ALREADY PROTECTED WITH Cirprotec.

Your luminaire, protected, tested and certified against overvoltages

At Cirprotec we ensure both the protection of the LED luminaire and the coordinated design between the luminaire and the arrester (SPD).

For manufacturers working with large scale projects, **Cirprotec provides testing and certification of luminaires in terms of resistance to overvoltages in accordance with standards, by an internationally accredited laboratory.**

ADD VALUE TO YOUR LUMINAIRE.

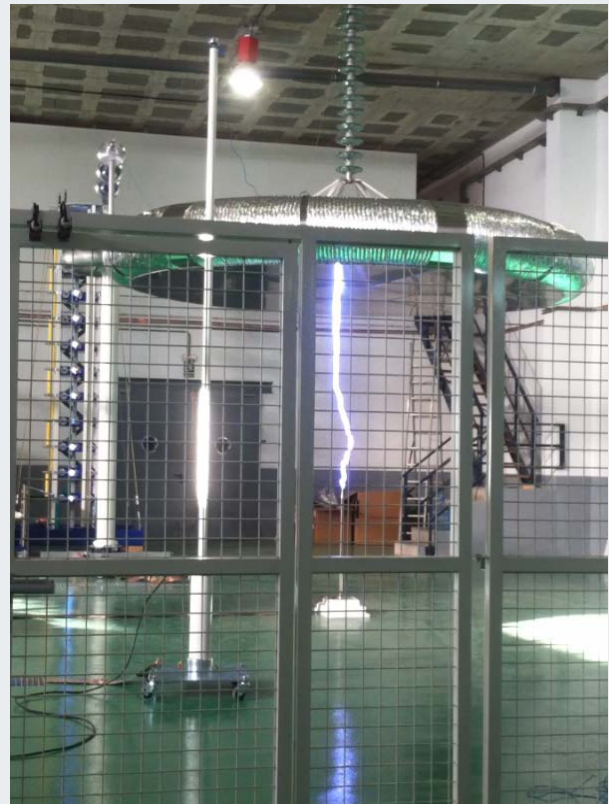

Protection of interior lighting

Interior luminaires are also exposed to overvoltages, caused chiefly by inductions through long runs of wiring.



SPECIALISTS IN LIGHTNING AND
SURGE PROTECTION

CIRPROTEC, S.L.

Lepanto 49 · 08223 TERRASSA · BARCELONA · SPAIN
Tel. +34 93 733 16 84 · Fax +34 93 733 27 64
export@cirprotec.com

www.cirprotec.com

